

ELIMINATE ENGINE VIBRATIONS AT SOURCE

VIBRATION COMPENSATORS

Engine vibrations cost money and harm your crew & vessel. But there's a simple, innovative solution. Gertsen & Olufsen's world-leading compensators eliminate vibrations at source, reducing costs, improving comfort, and cutting fuel consumption.

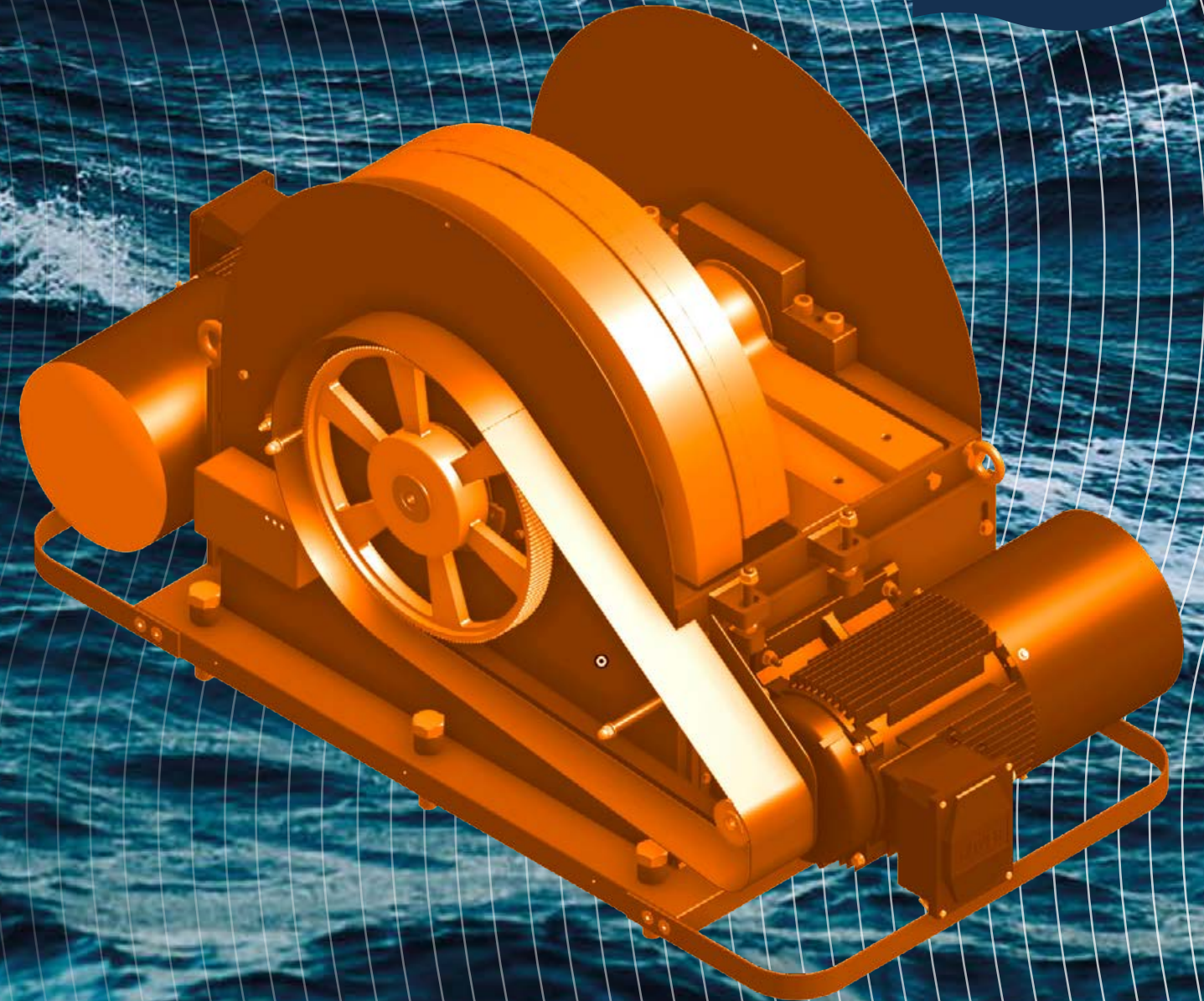



STOP THE VIBRATIONS AT SOURCE AND SAVE STEEL

It's an open secret that today's low speed two stroke engines generate severe forces and moment that could lead to damaging vibrations. Conventional countermeasures involve massive steel reinforcements yet often only have limited impact. Gertsen & Olufsen's compensators are a simple, highly effective alternative.



Large marine engines in combination with ship design generates vibrations that continually apply stress on vulnerable equipment, reduce operational flexibility and harm your crew's physical and mental health.

But conventional countermeasures merely focus on the symptom. Structural reinforcements, heavy counterweights and hydraulic top-stays add hundreds of tonnes of steel but only serve to dampen or transfer the vibration.

All of which can be saved by implementing the guide force free engine.

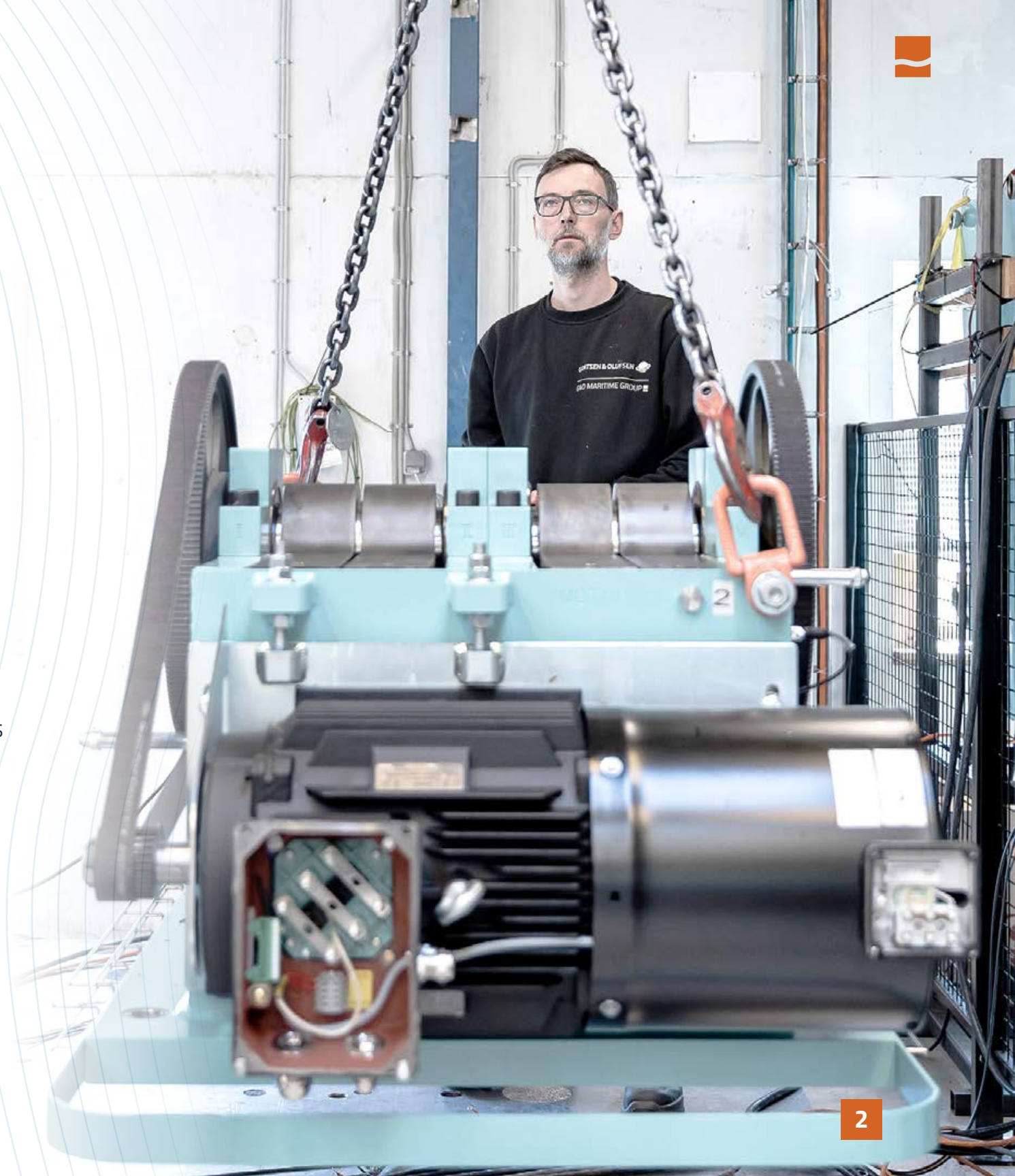

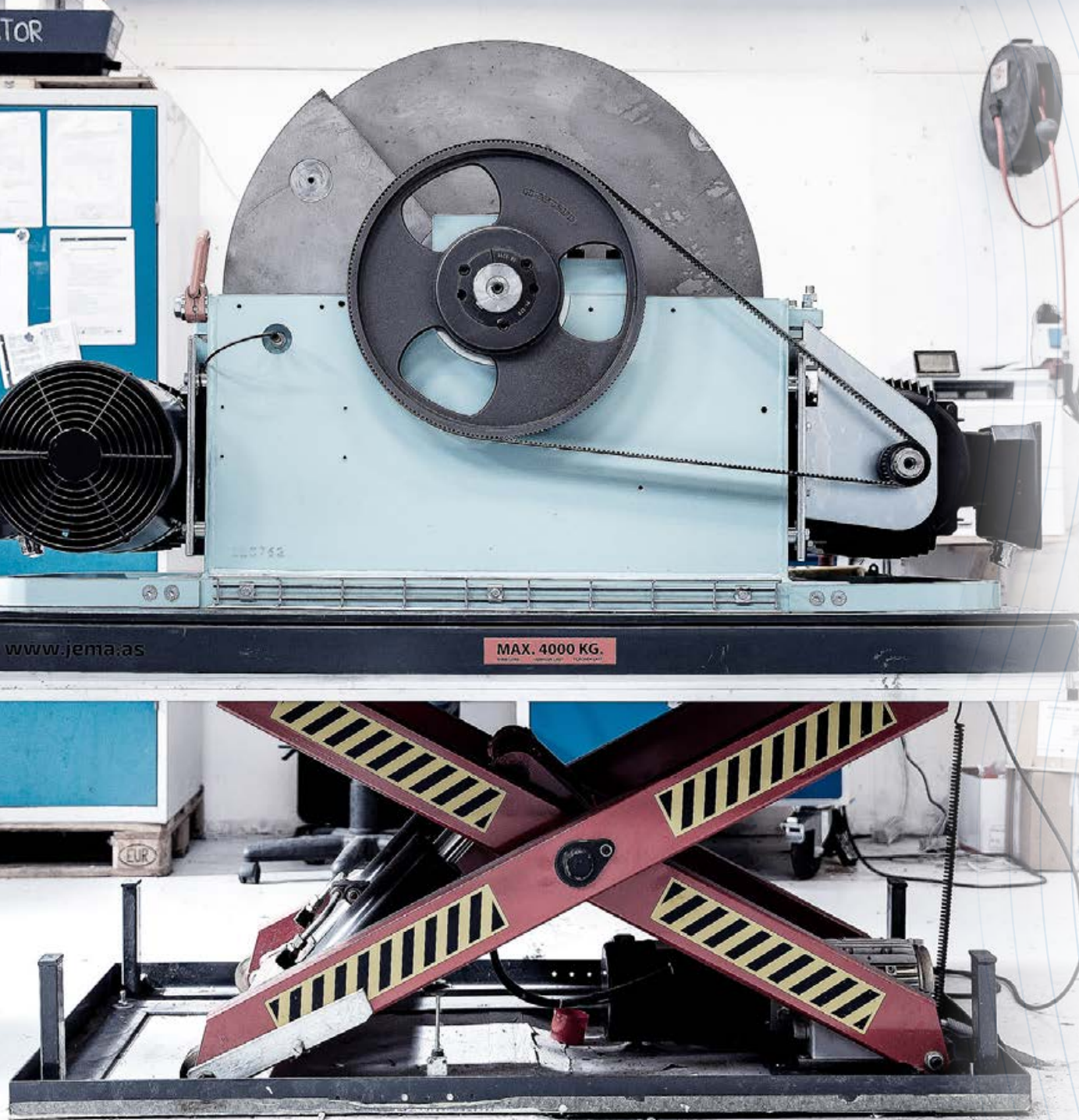

OUR APPROACH TO ELIMINATING VIBRATIONS

Our philosophy is to attack the source rather than the deal with symptom. When the engine moves, our compensator moves the other way. It's simple negative interference. The engine's force is balanced by a precisely calibrated counterforce enabling unrestricted engine operation, which contributes to fuel and emission savings – a critical factor as regulations inexorably tighten.

SMOOTHER, MORE EFFICIENT OPERATION – IN EVERY SENSE

- ~ Improved engine performance
- ~ Lower fuel consumption
- ~ Reduced maintenance costs
- ~ Easy installation – can be retrofitted during vessel operation
- ~ Automatic operation without crew input





WHY BOTHER ELIMINATING VIBRATIONS? YOU'LL DISCOVER SIGNIFICANT SAVINGS

The high levels of forces and moments produced by ultra-long two-stroke engines are clearly a challenge for the shipyards when integrated in a modern ship hull design. That's why hundreds of tonnes of steel reinforcements are typically welded around the engine room in an attempt to reduce and isolate the high excitation forces.

Vulnerable tank systems, LNG membranes, cargo pumps, piping systems, valves, coolers, electronic systems and other expensive

equipment are continually degraded by these vibrations – not to mention the awful effects on your crew.

Once you use a Gertsen & Olufsen compensator to eliminate the problem, you gain a number of important benefits.

- Lower construction costs
- Reduce size and weight of engine
- No need for heavy reinforcements
- Reduce wear and tear on equipment and electronics

- Save maintenance time and operational cost
- Gain operational flexibility
- Increase crew welfare and health
- Enable sailing at optimal RPM for unrestricted operation and reduced fuel consumption

APPROVED BY THE WORLD'S LEADING MANUFACTURERS

Our compensators are recommended by the top engine manufacturers, shipbuilders, ship owners and classification societies worldwide.



WHY GERTSEN & OLUFSEN?

Work with the global leader in the maritime and offshore industry

At Gertsen & Olufsen we apply brilliant design and quality engineering to solve the maritime industry's toughest and most pressing challenges.

We help you reduce costs, increase productivity and operate more sustainably, whether through innovative vibration compensators or bioreactors.

Since 1945, Gertsen & Olufsen has been one of the leading international partners for shipping operators, owners and builders worldwide. Today we have expanded into the G&O Maritime Group by joining forces with other world-leading maritime suppliers.

Together we develop a range of unique, advanced solutions for the maritime and offshore industries.



HOW THE GERTSEN & OLUFSEN COMPENSATOR WORKS

The **Gertsen & Olufsen** vibration compensator is a flexible system which is very precisely controlled to eliminate a range of different kinds of vibrations in a vessel – adjusting easily for the dramatic changes between a vessel in full load or ballast condition.

A very simple principle underlies the compensator. The device creates an exact opposite force to the force created by the engine. This interaction of positive and negative wave reduces or eliminates the vibration. The system is so effective that practically no excitation forces are transferred into engine foundation, hull and neighbouring structures.

3 KEY COMPONENTS

- 1** A synchronising unit controls the compensator, which specifies the precise frequency and phase angle.
 - 2** High torque electric motors drive counterrotating small mass-moments of fly-weights, creating sinusoidal excitation forces.
 - 3** The main engine RPM detection system detects the main engine rpm and TDC.
- Size of force can be adjusted from 0 to 100%, to get exact counterforce required. Adjustment range 1 kg
 - Direction of force can be adjusted from 0 to 360°, to achieve a precise direction of force +/- 1°
 - Unique frequency controller enables a fast and precise phase synchronisation





EASY INSTALLATION

Installation is a relatively simple project that does not interfere with the operation of the vessel. The compensator is normally delivered as a complete turnkey solution including cables, brackets, system components, installation and commissioning. At Gertsen & Olufsen we act as project managers right up to fine tuning the system.

EFFORTLESS OPERATION

Once the compensator is commissioned, no further adjustments or daily operational attention are needed. The compensator can be considered as an integrated part of the main engine. We recommend an overhaul (MTBO) every 20,000 hours.

TACKLING ANY SOURCE OF VIBRATION

Two stroke diesel engines generate two main kinds of vibrations, both of which can be tackled by the Gertsen & Olufsen compensator.

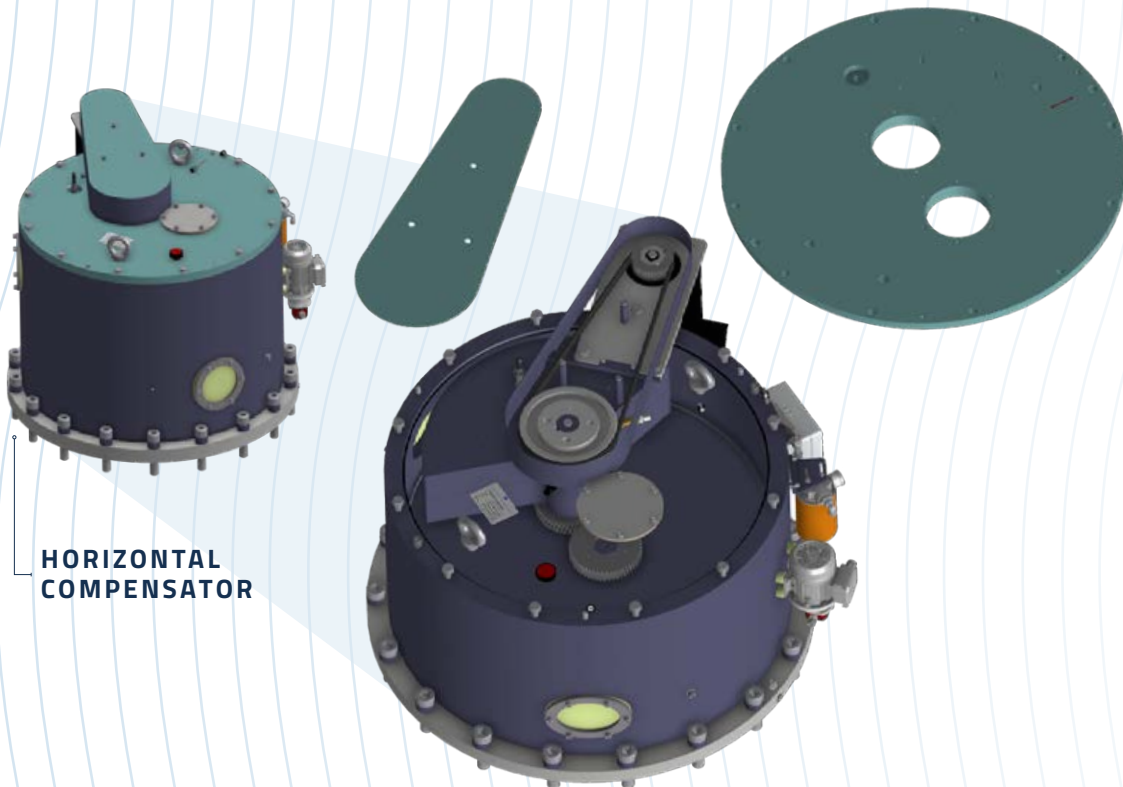

HORIZONTAL COMPENSATOR

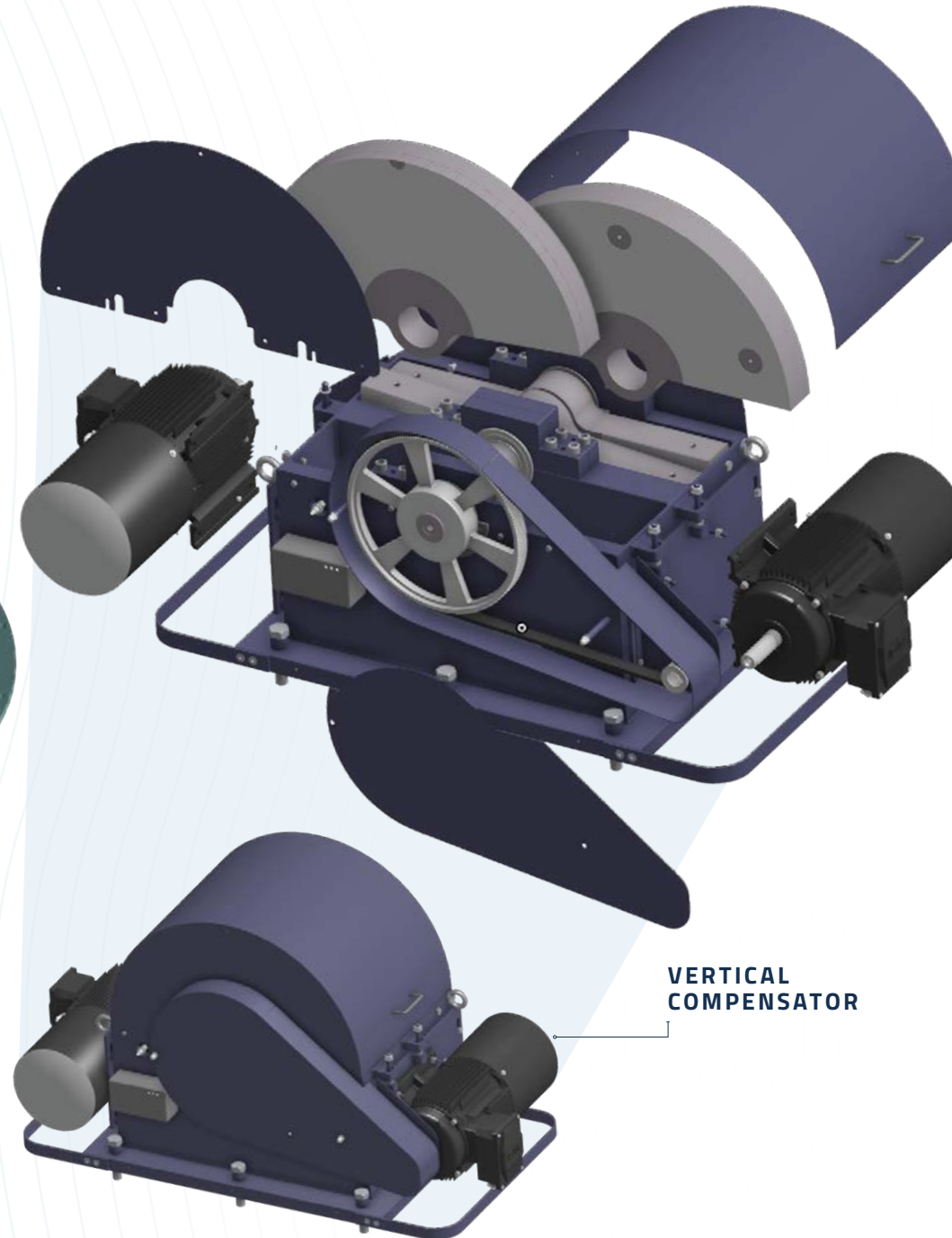

VERTICAL COMPENSATOR

GUIDE FORCE H MOMENTS

- ~ Horizontal rocking movement of the top of the engine
- ~ Conventional countermeasures often transfer the moment from the engine to elsewhere in the vessel
- ~ A horizontal compensator is mounted directly on the main engine gallery to eliminate the guide force

SECOND ORDER EXTERNAL MOMENTS

- ~ Vertical vibrations throughout hull
- ~ Conventional countermeasure is heavy built-in flyweights in the main engine, with only partial effectiveness
- ~ Alternatively a vertical compensator is mounted in the steering gear room
- ~ The distance from the engine creates an effective lever arm allowing the use of a smaller unit



SUPPORTED BY SUPERB GLOBAL SERVICE

When your compensator needs a service, we have service centres located at a number of strategic ports around the world offering 24/7 service to our customers.

Onsite service of your current compensator often involves downtime when the service takes place, and it can be a logistical hassle. Instead of onsite service, we offer to simply replace the entire unit with a unit that has already been overhauled at a G&O workshop, by our staff, with original spare parts.

The exchange of compensators takes up much less time than a full onsite service, saving you hassle and downtime. You save time and get a 24 month premium quality guarantee.





G&O MARITIME GROUP MARKET-LEADING BRANDS IN ONE PIONEERING GROUP

Gertsen & Olufsen is one part of the G&O Maritime Group, a global leader in the maritime and offshore industry.

G&O Maritime Group brings together a range of other strong brands each one a pioneer and market leader in their field. By joining forces, we are able to share resources and expertise and drive a greater range of products and competitive solutions.

Today we employ passionate people across the world with deep knowledge about the maritime industry. Our experience is vast, our products have delivered innovations to the industry over and over again, and we maintain a powerful environmental focus.

We are here to deliver advanced solutions to the maritime industry's biggest and toughest challenges.



Incineration of waste and oil sludge, eliminating the need for discharging to shore while reducing emissions from incineration.

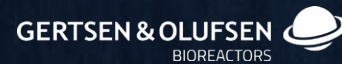

Biologically cleaning of grey and black waste water before it is discharged.



Leading global provider of cylinder lubrication systems for two stroke marine engines.



Piston rod stuffing boxes for two stroke engines continuously improved to live up to new fuel types entering the market.



Valves and venting equipment reducing emissions from cargo while keeping vessels, equipment and crews safe every day.



ENSURE YOUR VESSELS ARE READY FOR THE FUTURE

Gertsen & Olufsen compensators are the simple way to ensure your vessels run smoothly and efficiently. They can be retrofitted easily if needed or installed during construction to reduce vessel manufacturing costs.

Choose a simple solution to a serious problem that continually degrades your ships, equipment and crew. Reduce your operational costs while cutting fuel consumption and emissions. Above all, get ready for the challenges that lie ahead.

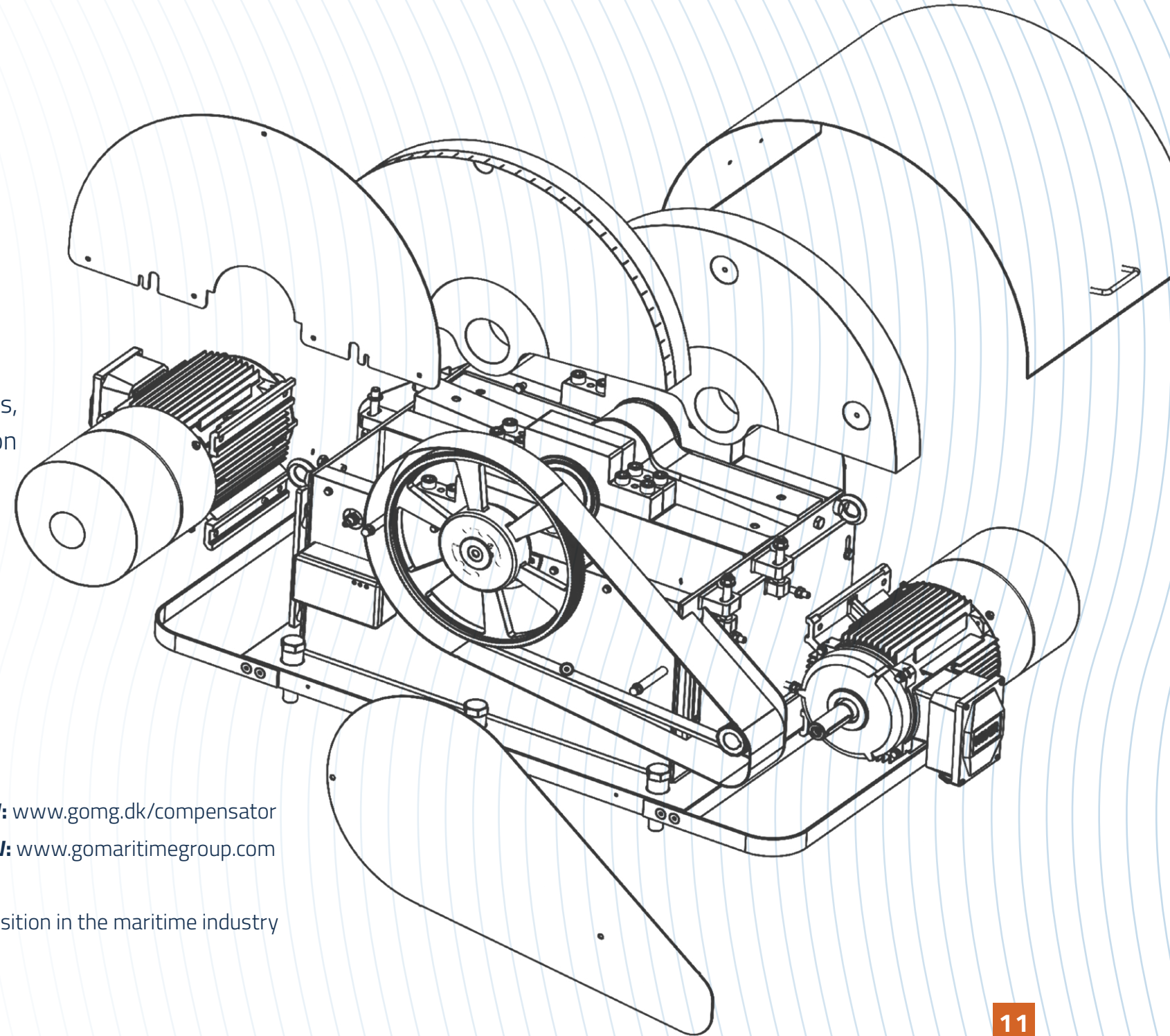

G&O MARITIME GROUP

Gertsen & Olufsen | Solvang 22 | DK-3450 Allerød | **E:** sales@g-o.dk | **W:** www.gomg.dk/compensator
G&O Maritime Group | Solvang 22 | DK-3450 Allerød | **E:** info@g-o.dk | **W:** www.gomaritimegroup.com

At G&O Maritime Group we enable our customers during the green transition in the maritime industry